

CASE STUDY

Creation of Digital Twin Geometry of Cabin Interior

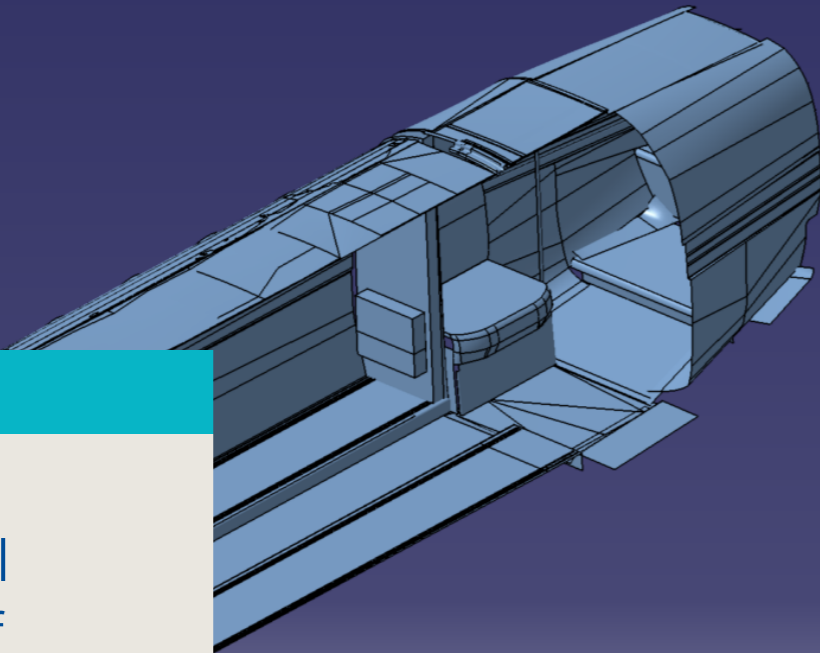

Task Objectives

A global specialist in aircraft conversions and integrations for special missions collaborated with AFD to craft a precise digital twin of the Beechcraft King Air interior using state-of-the-art 3D laser scanning technology combined with photogrammetry.

Photogrammetry a method that uses photographs to measure and create 3D models of physical objects and spaces.

The project was designed to simplify the retrofitting of new equipment for an Intelligence, Surveillance and Reconnaissance (ISR) platform.

To better facilitate the scanning, the aircraft interior was stripped, removing consoles, seats and other components, leaving only the interior panelling and flooring.

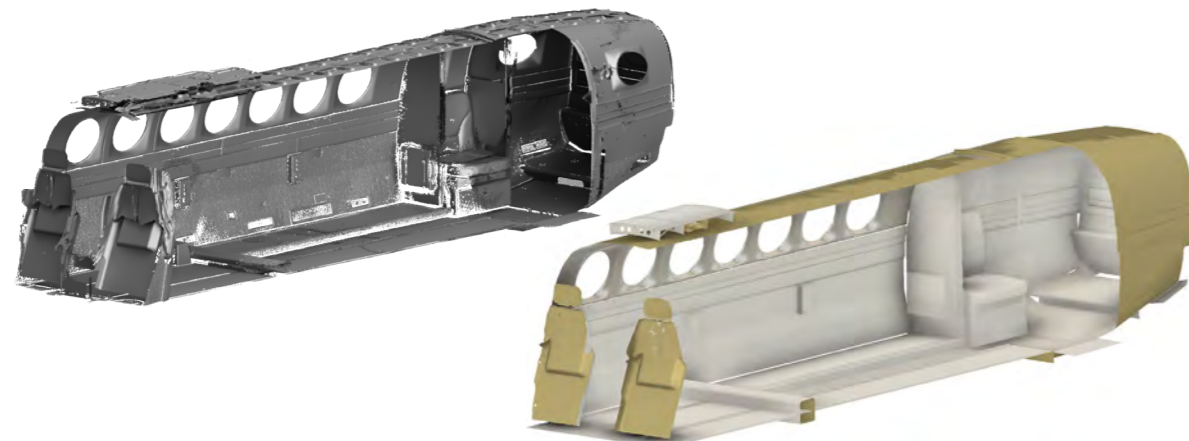

Scanning Methodology

The latest in 3D scanning technology was used to ensure the work was delivered ontime and at the highest achievable quality.

The aircraft interior was scanned in its existing state to plan how to best use the space available for the retrofit, and to establish base-line geometry.

The AFD scanner utilises advanced photogrammetry technology for large-scale scans of this nature, in order to achieve industry-leading accuracy of 50 microns/metre.

Despite ongoing maintenance on the aircraft, AFD engineers efficiently completed a comprehensive on-site 3D scan in just two days, ensuring both activities progressed simultaneously.

Conclusion

In just two days, AFD was able to complete the on-site scan of the aircraft interior using industry-leading technology with efficiency and accuracy.

The collected data was subsequently transformed into a digital twin and an engineering CAD model, taking a further five days of post-processing in our engineering office.

With a commitment to excellence in engineering, we ensure our customers receive timely solutions to the highest standard of service every step of the way.

Additional Challenges

A local section of ceiling structure was scanned in finer detail for the purpose of retrofitting a new external antenna. This necessitated the scanning of the airframe skin, frames, stringers, pipes, cables, and ducting.

Our team managed to generate accurate and high quality scans of this local area in accordance with the customer requirements, and subsequently converted the data cloud of point geometry into usable 3D CAD models.



“AFD solved a real headache with their proposal to 3D scan the cabin interior to create a digital twin CAD model. This enabled the programme to move forward at pace with reduced risk.”

Head of Design

Contact the specialist team at AFD Systems to discuss your next complex manufacturing challenge **03330 150 563**



Visit our website